

SPECIAL BEARINGS FOR INDUSTRIAL APPLICATIONS
CUSCINETTI SPECIALI PER L'INDUSTRIA

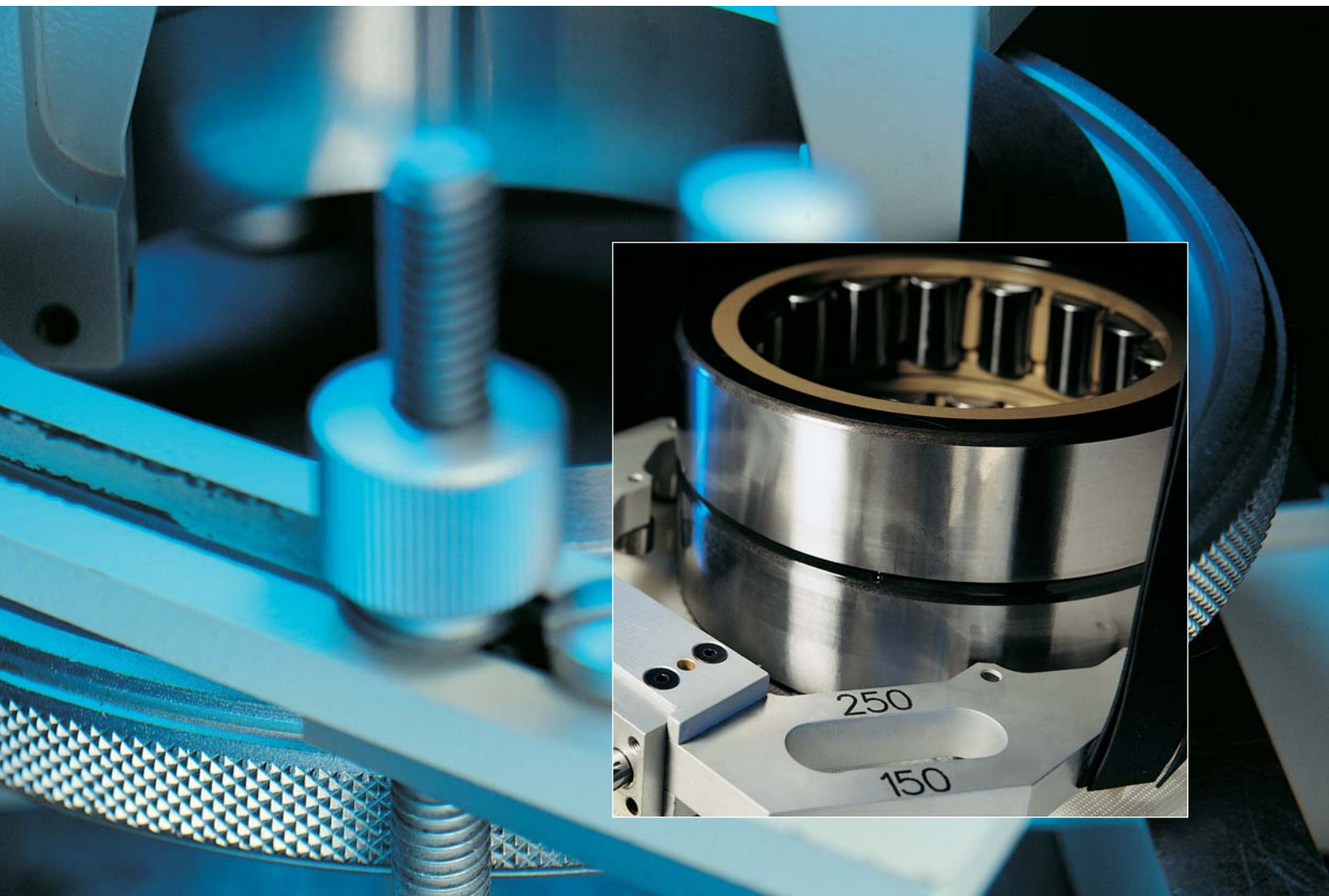

A WORLDWIDE
ORGANIZATION

UN'ORGANIZZAZIONE
GLOBALE



UNITEC is a leading company in the design and manufacturing of special bearings for industrial applications and precision cylindrical roller bearings for machine tools and general industry.

UNITEC is a certified ISO 9001 and ISO 14001 company and provides high quality service to customers worldwide: vast engineering know-how, technical and logistic assistance and a widespread commercial network.

UNITEC belongs to Mondial Group, whose parent company is Mondial S.p.A.. Besides representing top class suppliers on the Italian market, Mondial also manufactures customized products which are able to meet the toughest operating and environmental challenges, catering for requirements in most industrial sectors worldwide. Other companies belonging to Mondial Group are:

ITM-UNITEC, a company that distributes the wide range of UNITEC products on the German market with a focus on bearings for industrial applications like steel and metal industry, paper industry, screw extruders and for various application fields.

TMT a company specialized in development and manufacture of linear systems with head office in Milan.

UNITEC è leader nella progettazione e costruzione di cuscinetti speciali per il settore industriale e produce cuscinetti di precisione a rulli cilindrici per macchine utensili.

UNITEC è certificata ISO 9001 e ISO 14001 e ai propri clienti in tutto il mondo, offre servizi di elevata qualità come l'assistenza tecnica qualificata sin dalle prime fasi del progetto, una rete commerciale capillare, un servizio postvendita affidabile e costantemente adeguato alle esigenze del mercato.

UNITEC fa inoltre parte del Gruppo Mondial la cui capo-gruppo, Mondial S.p.A., oltre a rappresentare primarie società estere, progetta e produce un'ampia gamma di prodotti speciali in grado di risolvere le più diverse esigenze in molti settori industriali.

Fanno parte del gruppo:

ITM-UNITEC che distribuisce l'ampia gamma dei prodotti UNITEC sul mercato tedesco, con particolare attenzione ai cuscinetti per applicazioni in settori industriali quali la siderurgia, l'industria cartaria, estrusori a vite oltre ad altri settori.

TMT, specializzata nella progettazione e nella produzione di sistemi lineari.



Located near Piacenza at the crossroads of the major arteries that connect Italy with the rest of Europe, UNITEC production plant extends over an area of 30,000 Sqm of which 12,000 are covered.

The production plant is organized in two main areas: precision cylindrical roller bearings and special bearing for the industry. The plant is equipped with automated processes and the most recent machine tool technology. At each stage of the production, specialized personnel perform on-site quality controls to ensure that UNITEC products conform to ISO 9001 standards and to the design specifications based on customer requirements.

UNITEC production capacity

- Minimum bore diameter: 8 - 10 mm;
- Maximum outer diameter: 800 mm;
- Precision: from P0 to P4, UP;
- Material for rings: 100Cr6 and 100CrMo7 through hardening steel, 18NiCrMo5 case hardening steel, stainless steel and other steels for special applications;
- Material for cage: bronze, ergal, aluminum, polyamides, stainless steel or other suitable for special applications.

Situato nei pressi di Piacenza al crocevia delle più importanti arterie che collegano l'Italia con il resto d'Europa, lo stabilimento produttivo UNITEC si estende in un'area di 30.000 m² di cui 12.000 coperti.

L'assetto produttivo è organizzato nelle due aree principali: cuscinetti di precisione a rulli cilindrici e cuscinetti speciali per l'industria ed è dotato di processi automatizzati e di macchine utensili all'avanguardia. Ad ogni fase della produzione, personale specializzato effettua on-site severi controlli di qualità, che garantiscono la conformità dei prodotti UNITEC non solo alla norme ISO 9001 ma anche ai disegni di progettazione realizzati sulla base delle esigenze applicative del cliente.

Capacità produttiva UNITEC

- Foro minimo: 8 - 10 mm;
- Diametro esterno max: 800 mm;
- Precisione: da P0 a P4, UP;
- Materiale per anelli: Acciaio tutta temprato 100Cr6, 100CrMo7; Acciaio da cementazione 18NiCrMo5; Acciaio Inox o altri per applicazioni speciali;
- Gabbie: in bronzo, ergal, alluminio, poliammide, inox o altro conforme all'applicazione.



CEAT
ENGINEERED BEARINGS

CONTENTS - INDICE

- Cylindrical roller bearings for radial, axial or combined loads, with cage or full complement; self-aligning bearings.
Cuscinetti a rulli cilindrici: radiali, assiali, combinati, con gabbia, a pieno riempimento, autoallineanti.
..... p. 6
- Wheels, flanged wheels, track rollers, cam followers: with seals, without seals.
Ruote e ruotini, rulli di contrasto, rotelle e perni folli: con tenute, senza tenute.
..... p. 8
- Rolling mills and steel industry: multi-row radial bearing for rolling mills, special bearings for sendzimir mills.
Laminazione e siderurgia: cuscinetti a più corone di rulli per cilindri di laminazione, cuscinetti per laminatoi tipo sendzimir.
..... p. 10
- Metal sheet manufacturing industry: straightening rollers.
Macchine per la lavorazione della lamiera: rulli e controrulli per spianatrici (radiali/assiali e con tenute)
..... p. 12
- Customized precision bearings for machine tools: special crossed roller bearings, combined bearings, spindle bearings with cylindrical or tapered bore.
Cuscinetti speciali per macchina utensile: a rulli incrociati, combinati assiali radiali, cuscinetti mandrino con foro cilindrico o conico.
..... p. 14
- Tandem bearings for single or twin screw extruders.
Cuscinetti multistadio assiali per estrusori.
..... p. 16
- Multi-row radial bearings: inner rings with rollers, outer rings with rollers, complete assemblies.
Cuscinetti a rulli cilindrici a più corone: anelli interni con rulli, anelli esterni con rulli, gruppi completi.
..... p. 18
- Customized ball bushings, integrated solutions.
Bussole di scorrimento assiale, manicotti speciali, soluzioni integrate.
..... p. 20

CYLINDRICAL ROLLER BEARINGS CUSCINETTI A RULLI CILINDRICI

Cylindrical roller bearings for radial, axial or combined loads, with cage or full complement; self-aligning bearings.

Cuscinetti a rulli cilindrici: radiali, assiali, combinati, con gabbia, a pieno riempimento, autoallineanti.

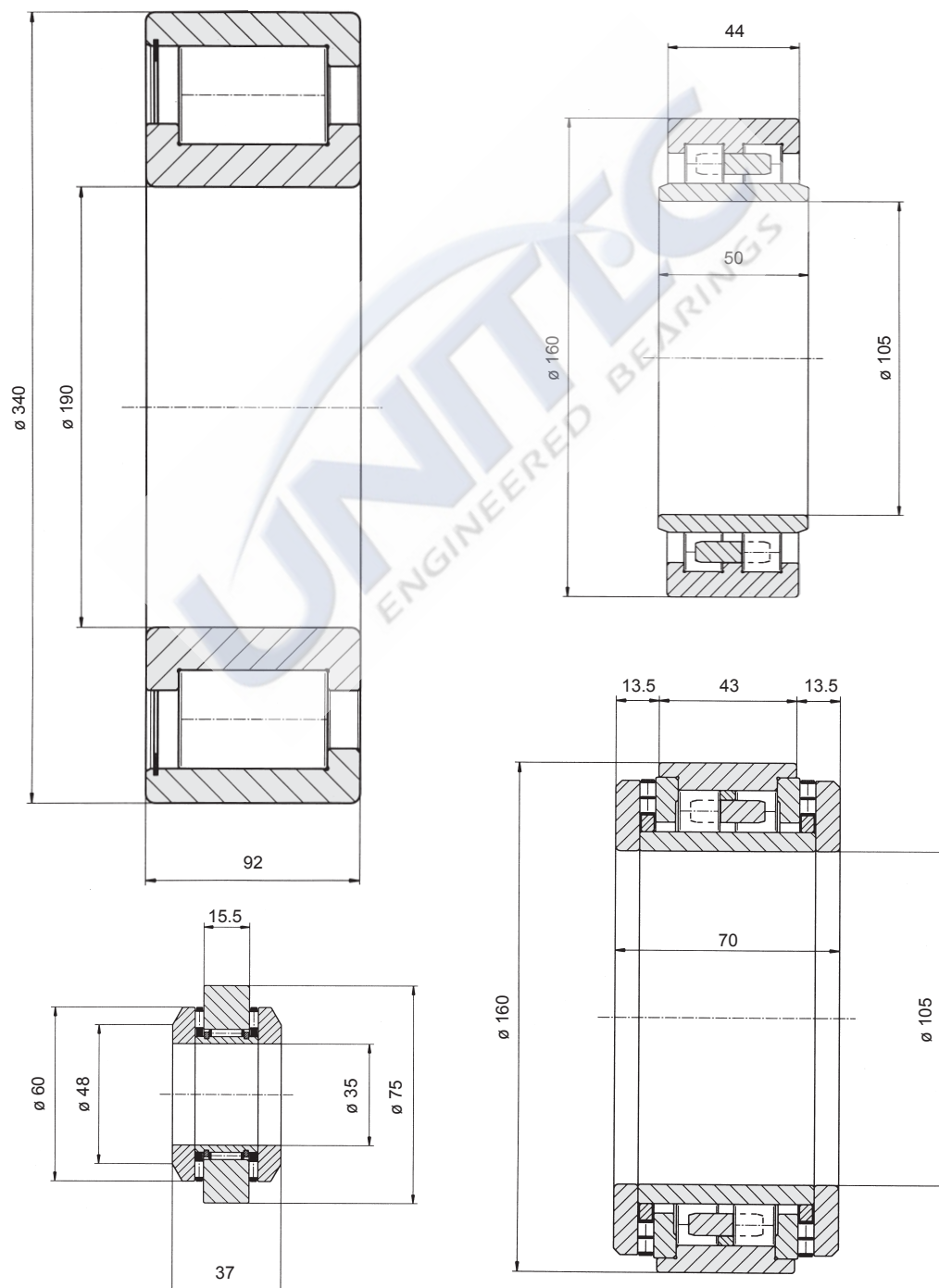



CYLINDRICAL ROLLER BEARINGS
CUSCINETTI A RULLI CILINDRICI

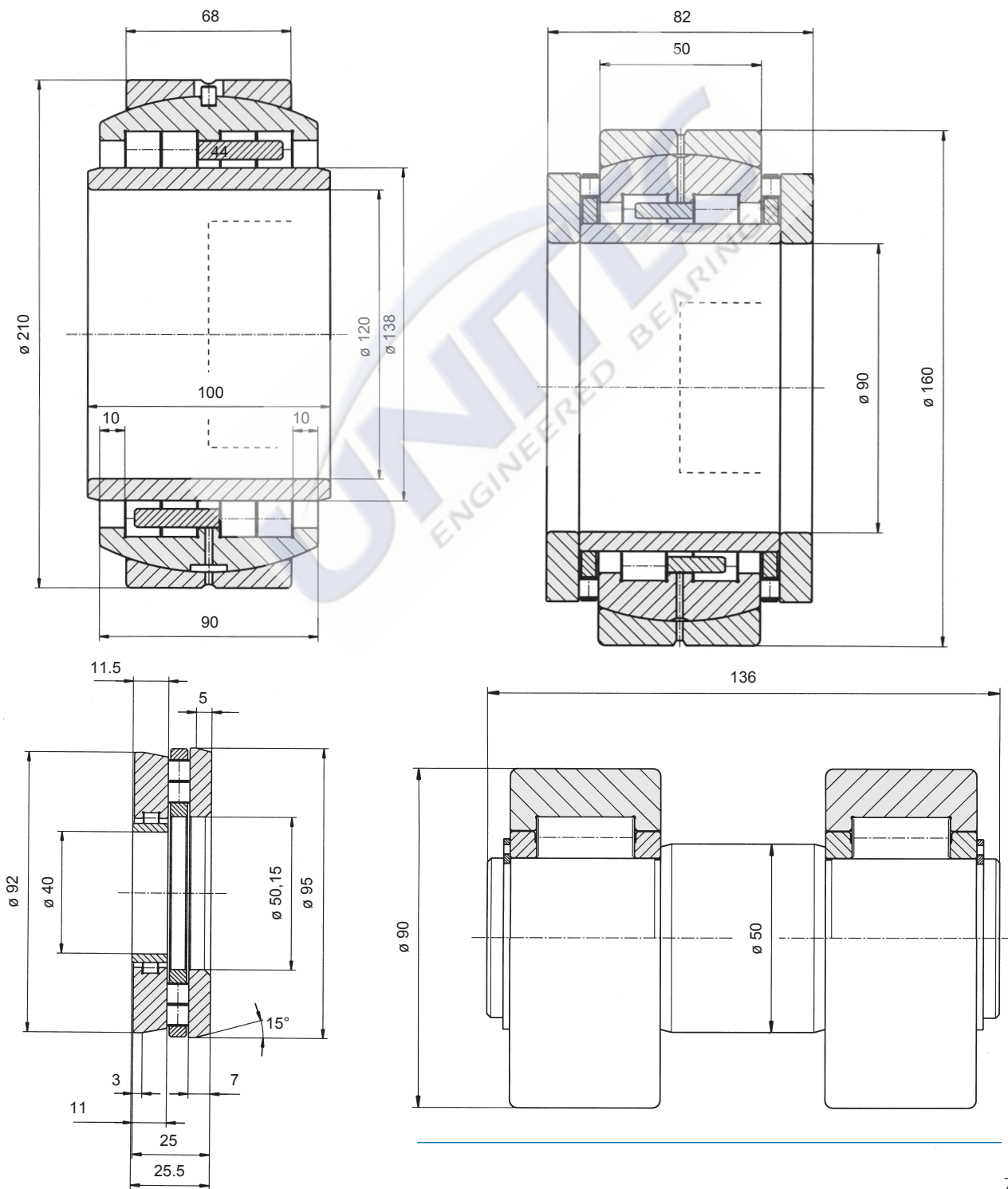

WHEELS, FLANGED WHEELS RUOTE E RUOTINI

Wheels, flanged wheels, track rollers, cam followers: with seals, without seals.
Ruote e ruotini, rulli di contrasto, rotelle e perni folli: con tenute, senza tenute.

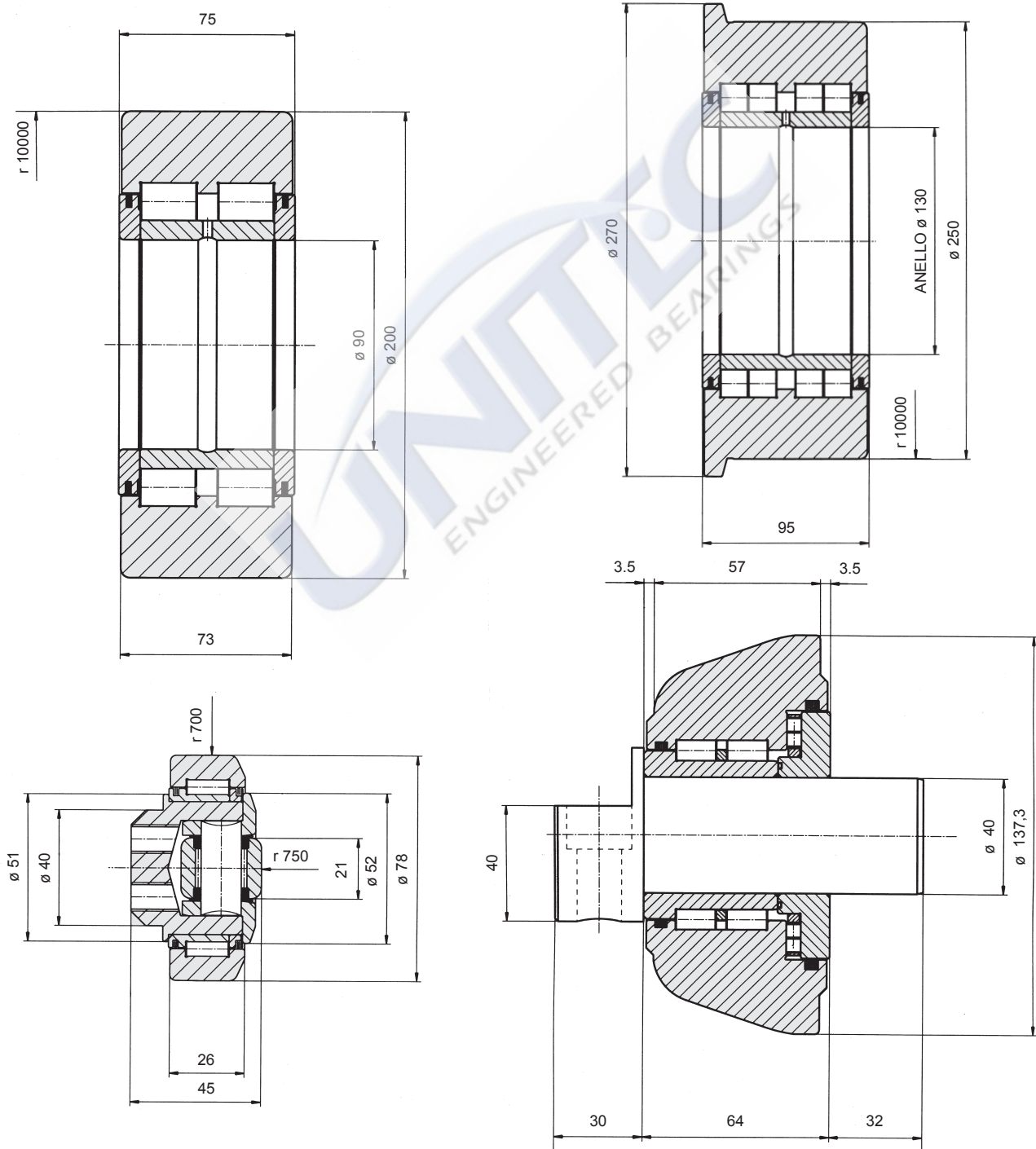



WHEELS, FLANGED WHEELS
RUOTE E RUOTINI

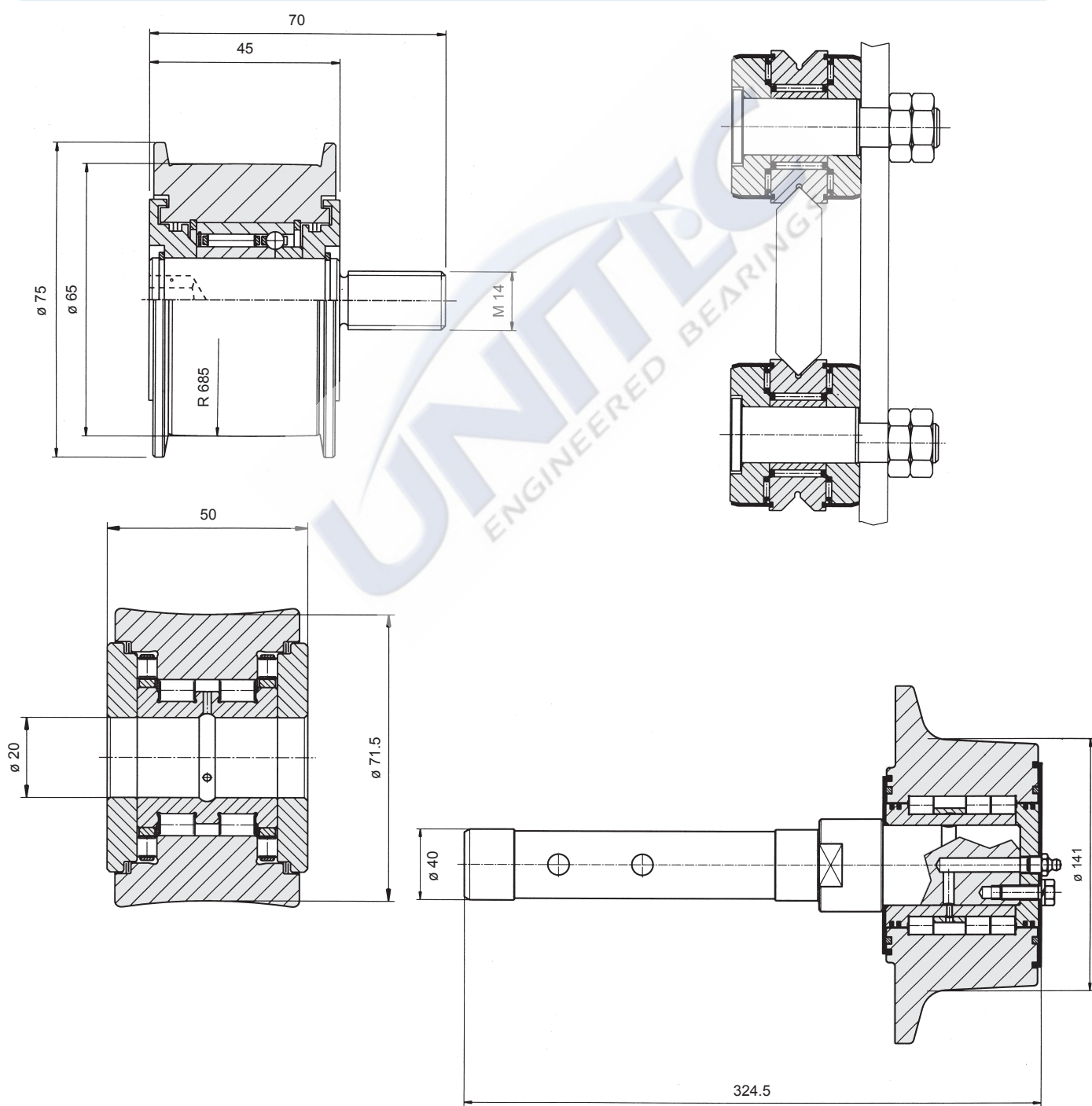

MULTI-ROW RADIAL BEARINGS CUSCINETTI A PIÙ CORONE DI RULLI

Rolling mills and steel industry: multi-row radial bearings for rolling mills, special bearings for Sendzimir mills.

Laminazione e siderurgia: cuscinetti a più corone di rulli per cilindri di laminazione, cuscinetti per laminatoi tipo sendzimir.

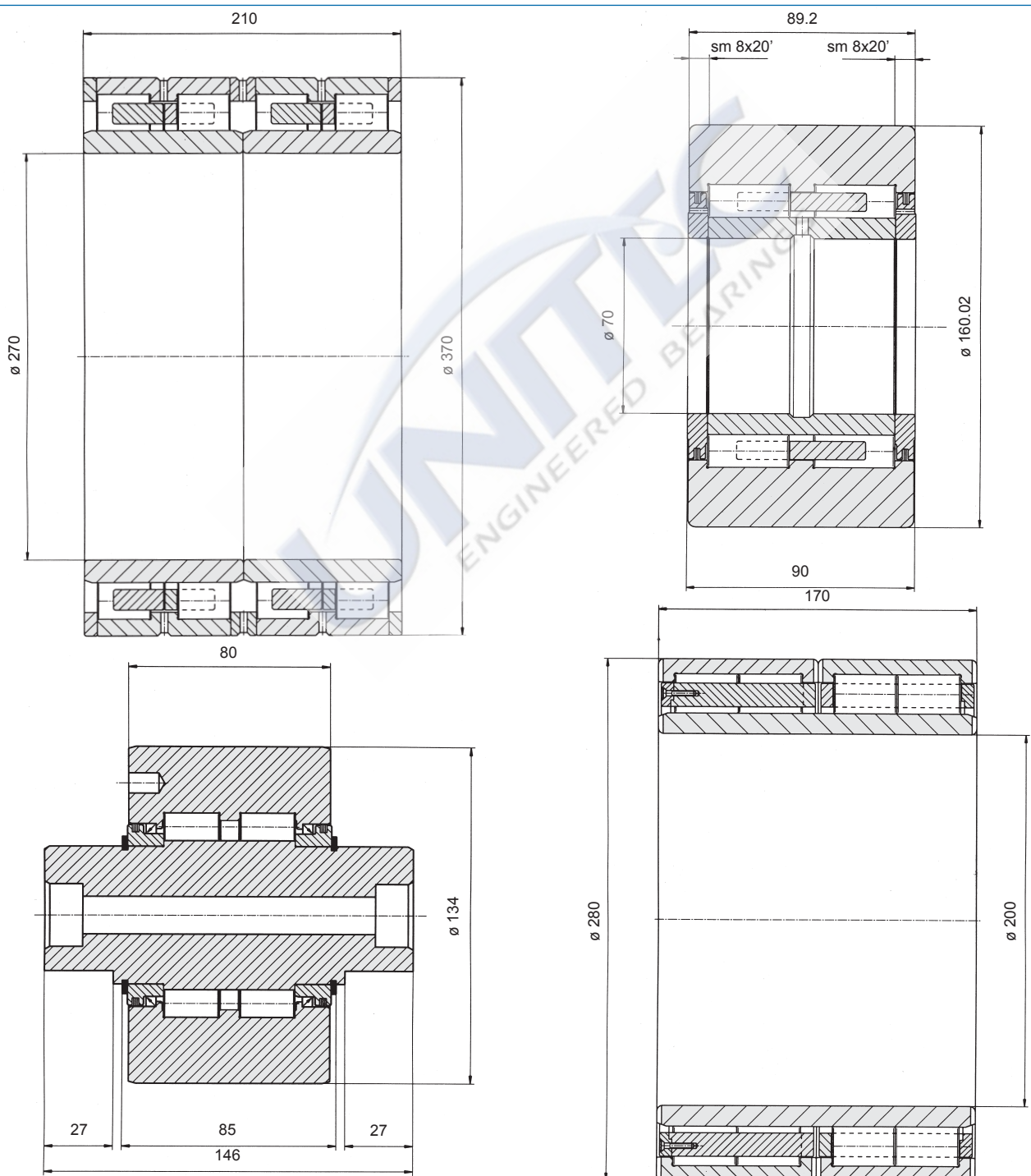

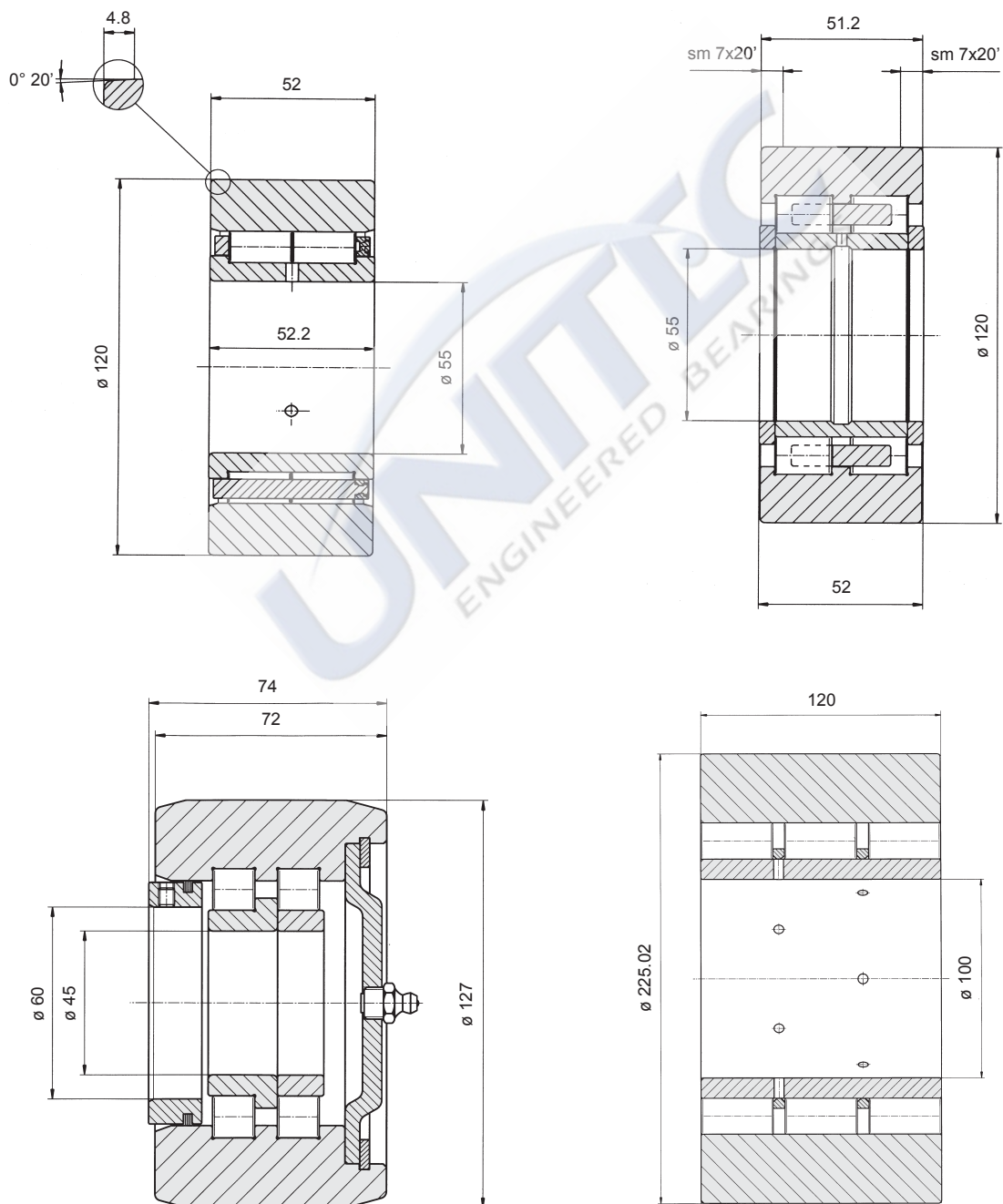

STRAIGHTENING ROLLERS RULLI E CONTRORULLI

Metal sheet manufacturing industry: straightening rollers.
Macchine per la lavorazione della lamiera: rulli
e controrulli per spianatrici (radiali/assiali e con tenute).

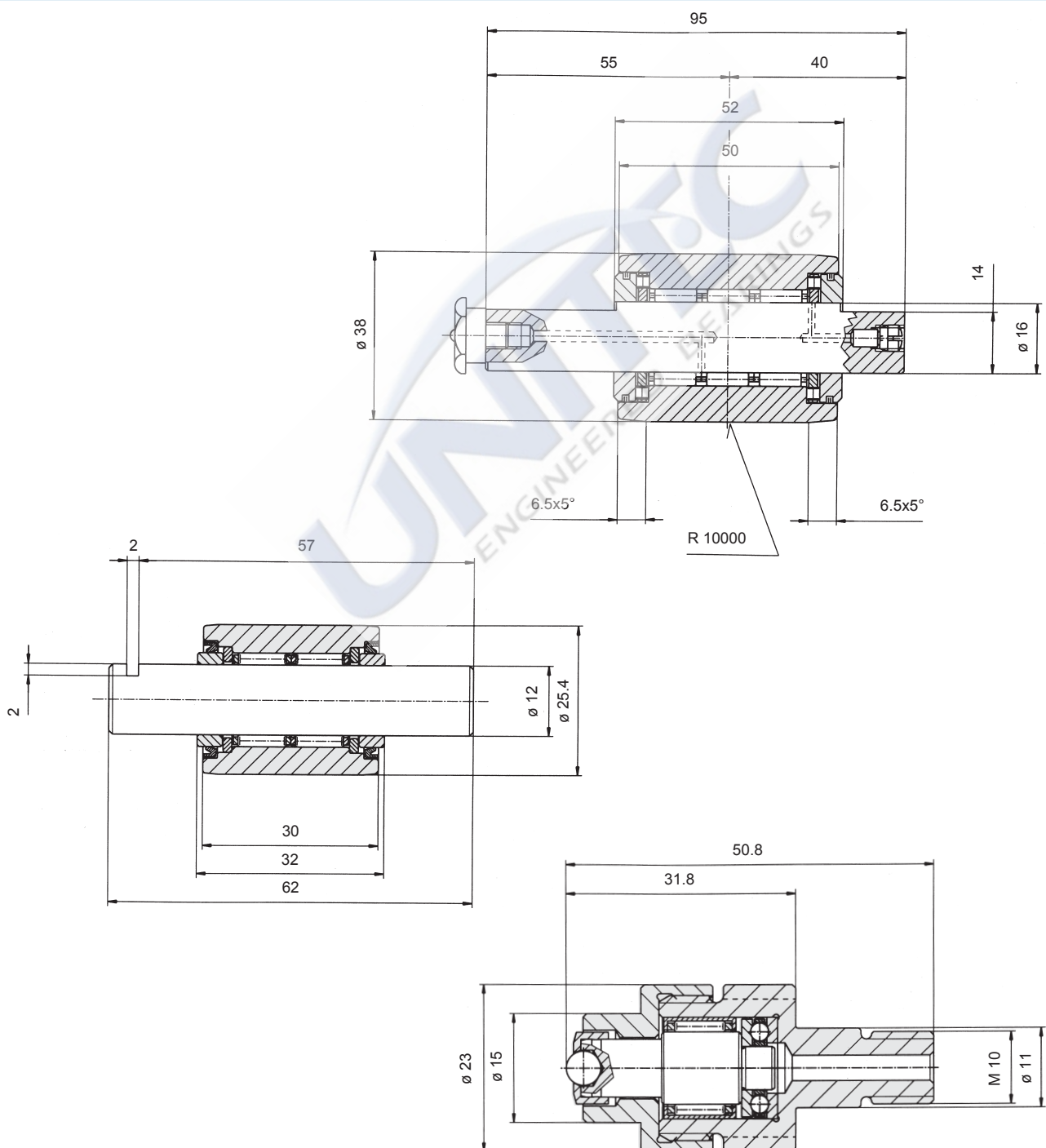

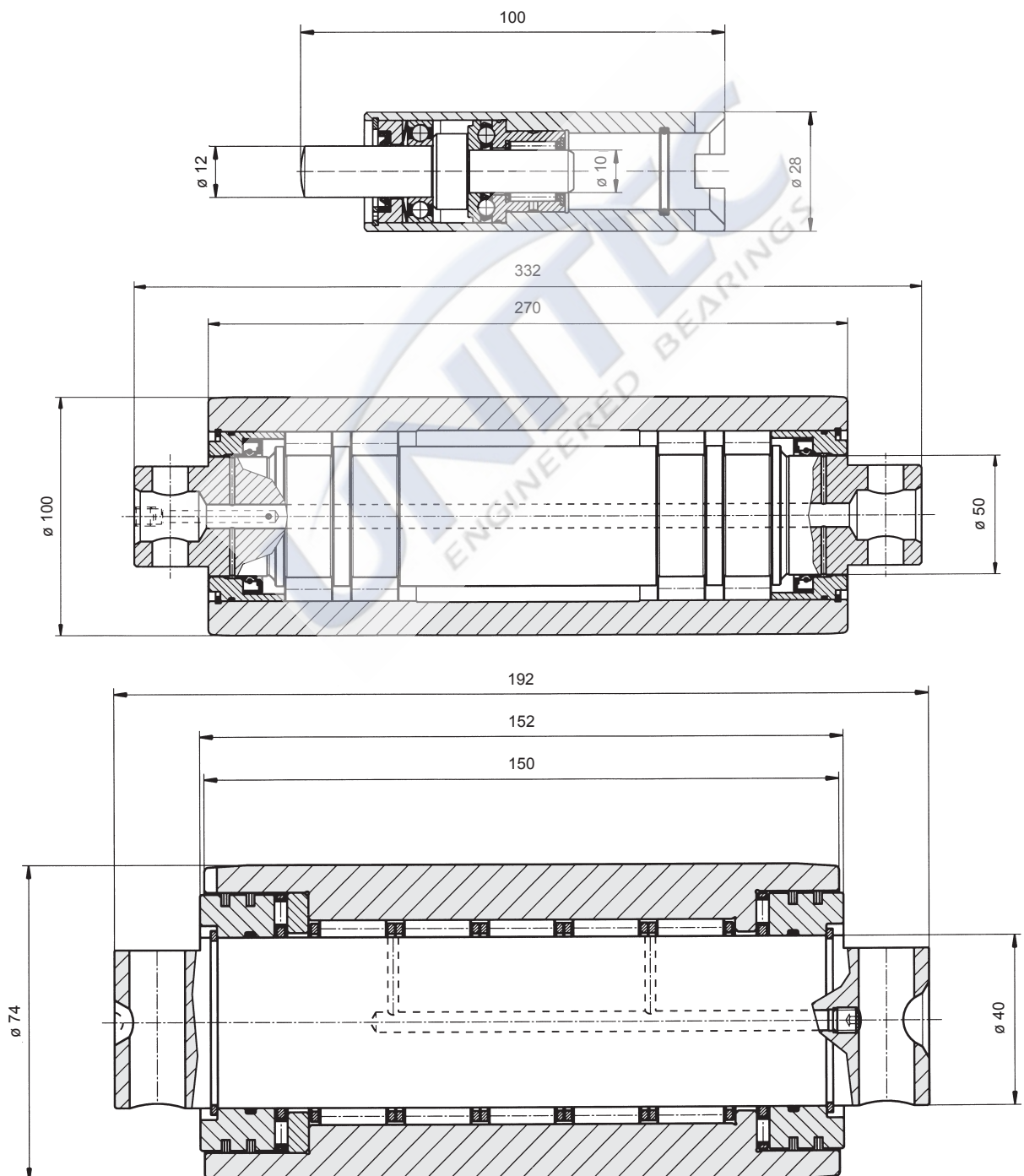
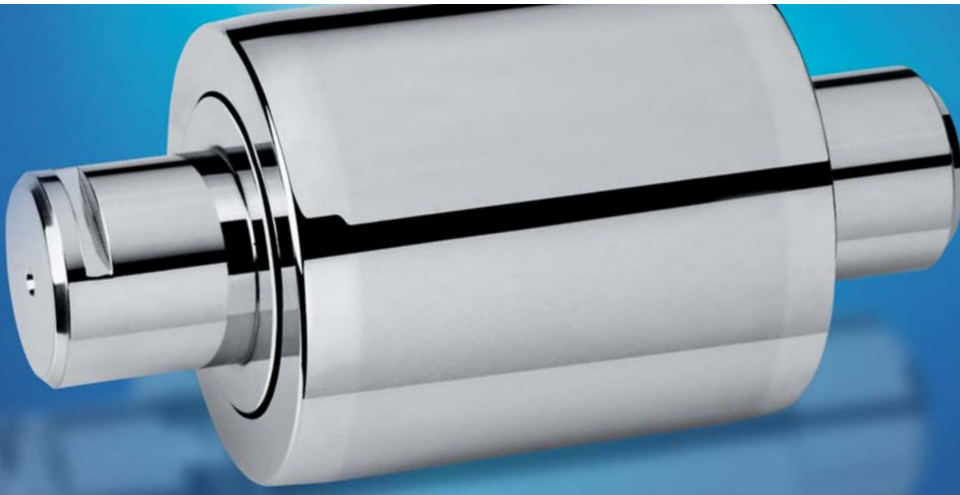

CUSTOMIZED PRECISION BEARINGS CUSCINETTI SPECIALI

Customized precision bearings for machine tools: special crossed roller bearings, combined bearings, spindle bearings with cylindrical or tapered bore.

Cuscinetti speciali per macchina utensile: a rulli incrociati, combinati assiali-radiali, cuscinetti mandrino con foro cilindrico o conico.

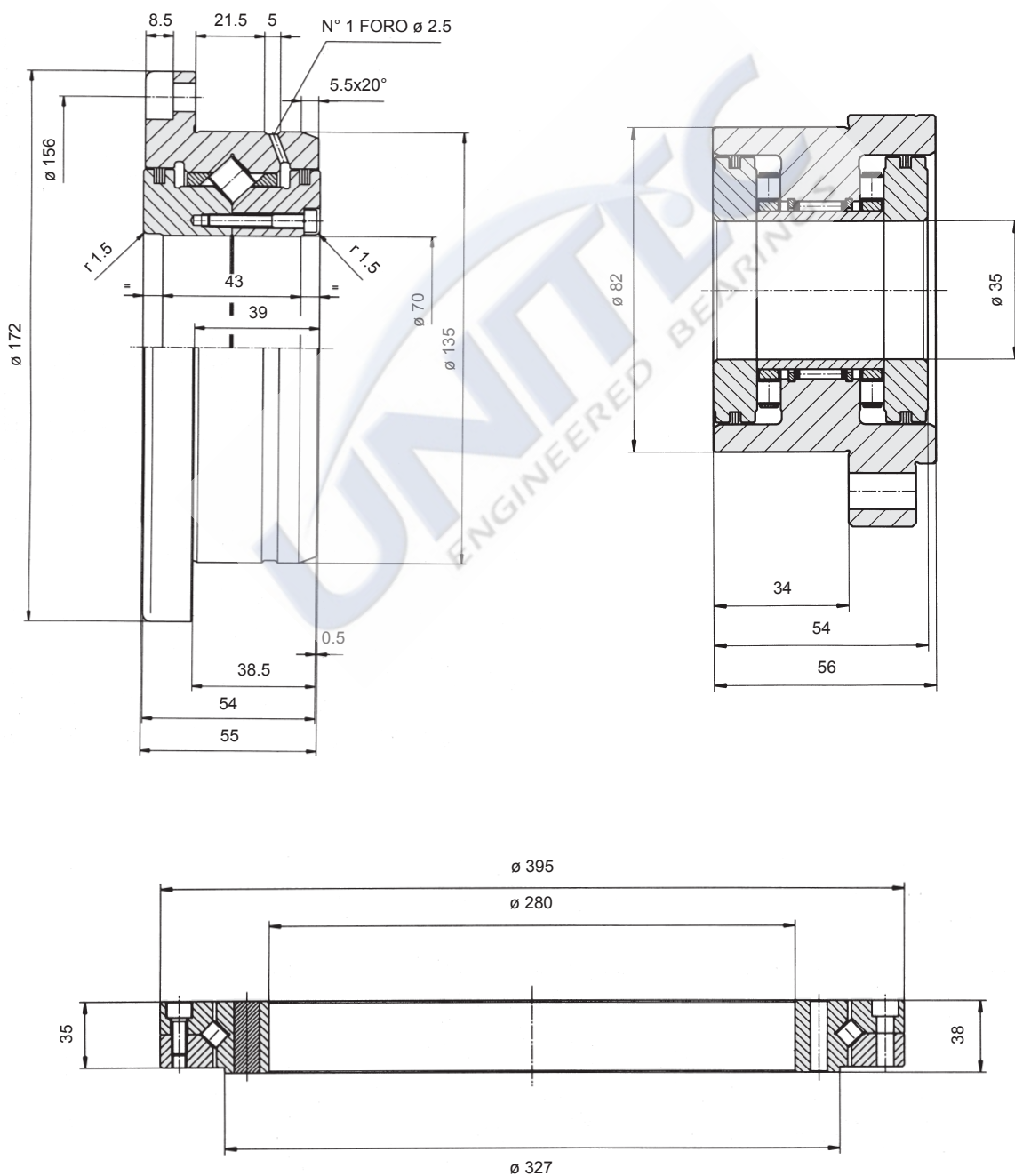

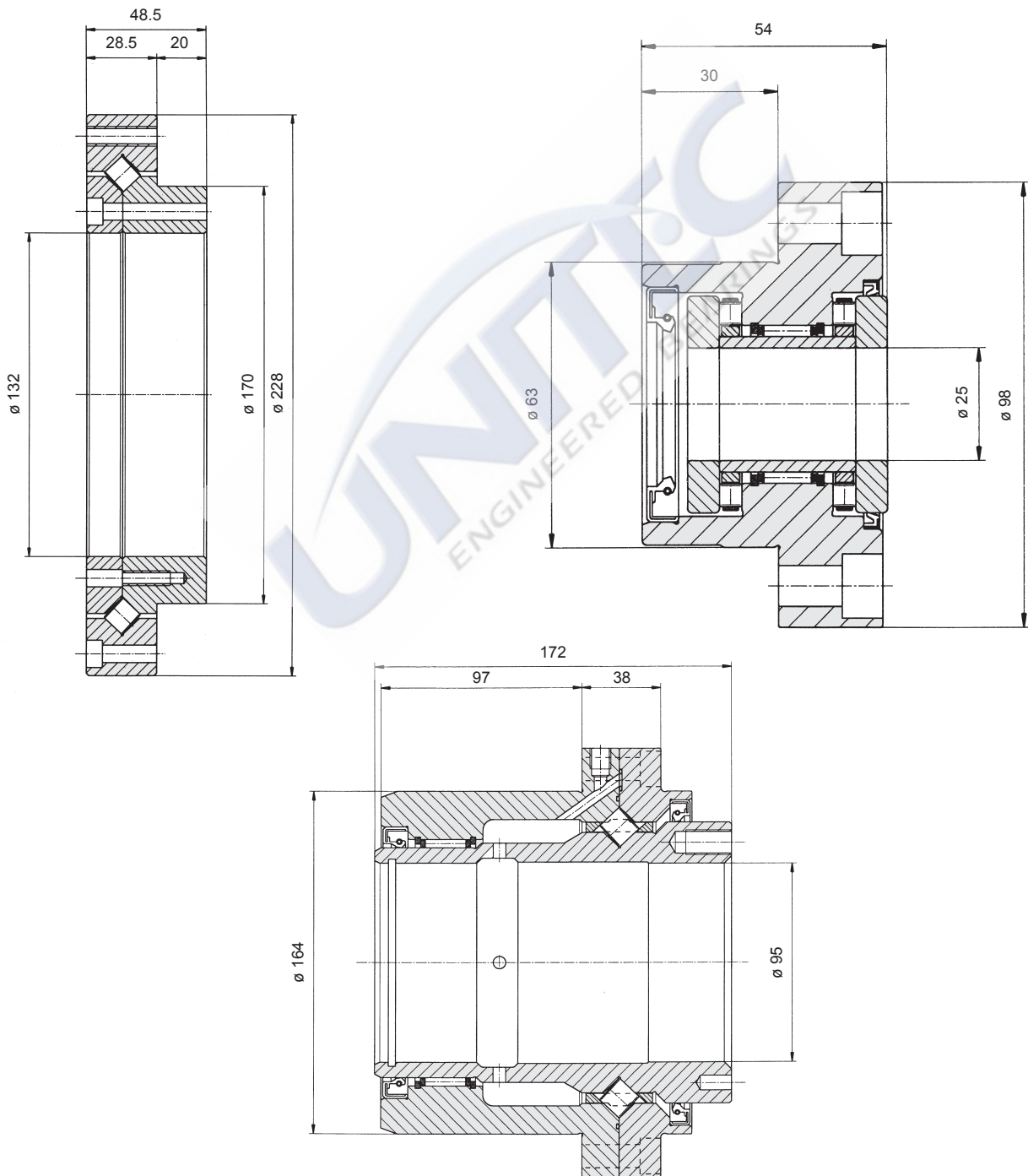

TANDEM BEARINGS

CUSCINETTI MULTISTADIO

Tandem bearings for single or twin screw extruders.
Cuscinetti multistadio assiali per estrusori.

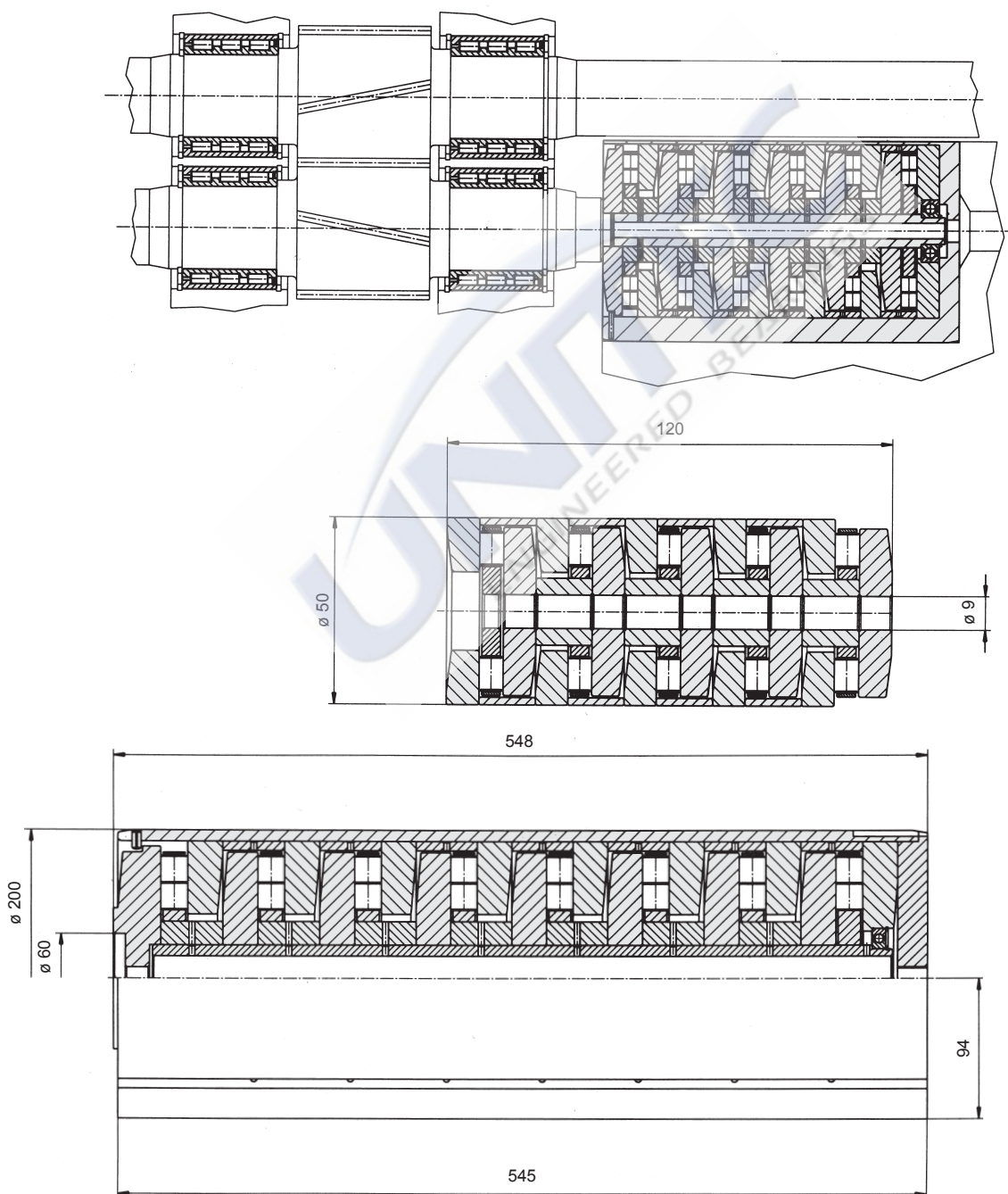

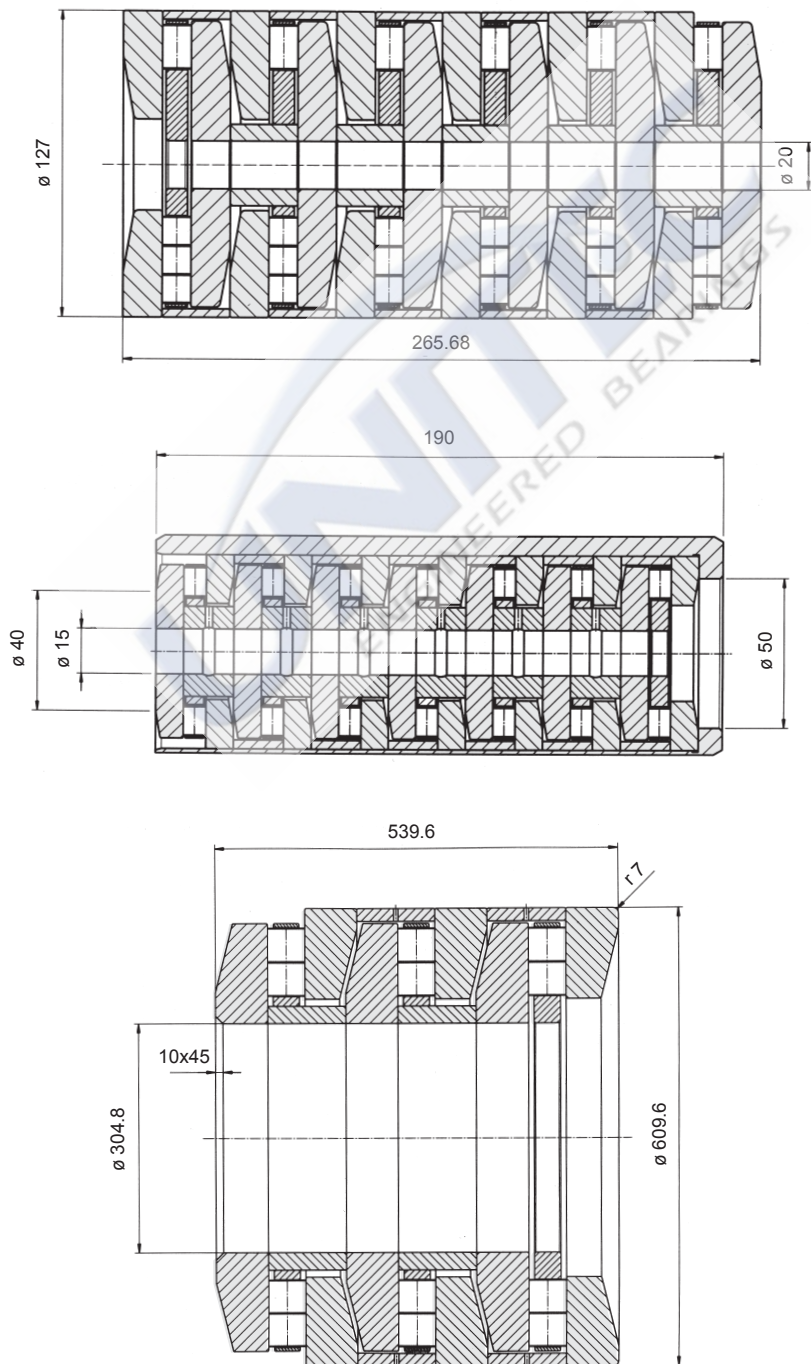

RINGS AND COMPLETE ASSEMBLIES

ANELLI E GRUPPI

Multi-row radial bearings: inner rings with rollers, outer rings with rollers, complete assemblies.

Cuscinetti a rulli cilindrici a più corone: anelli interni con rulli, anelli esterni con rulli, gruppi completi.

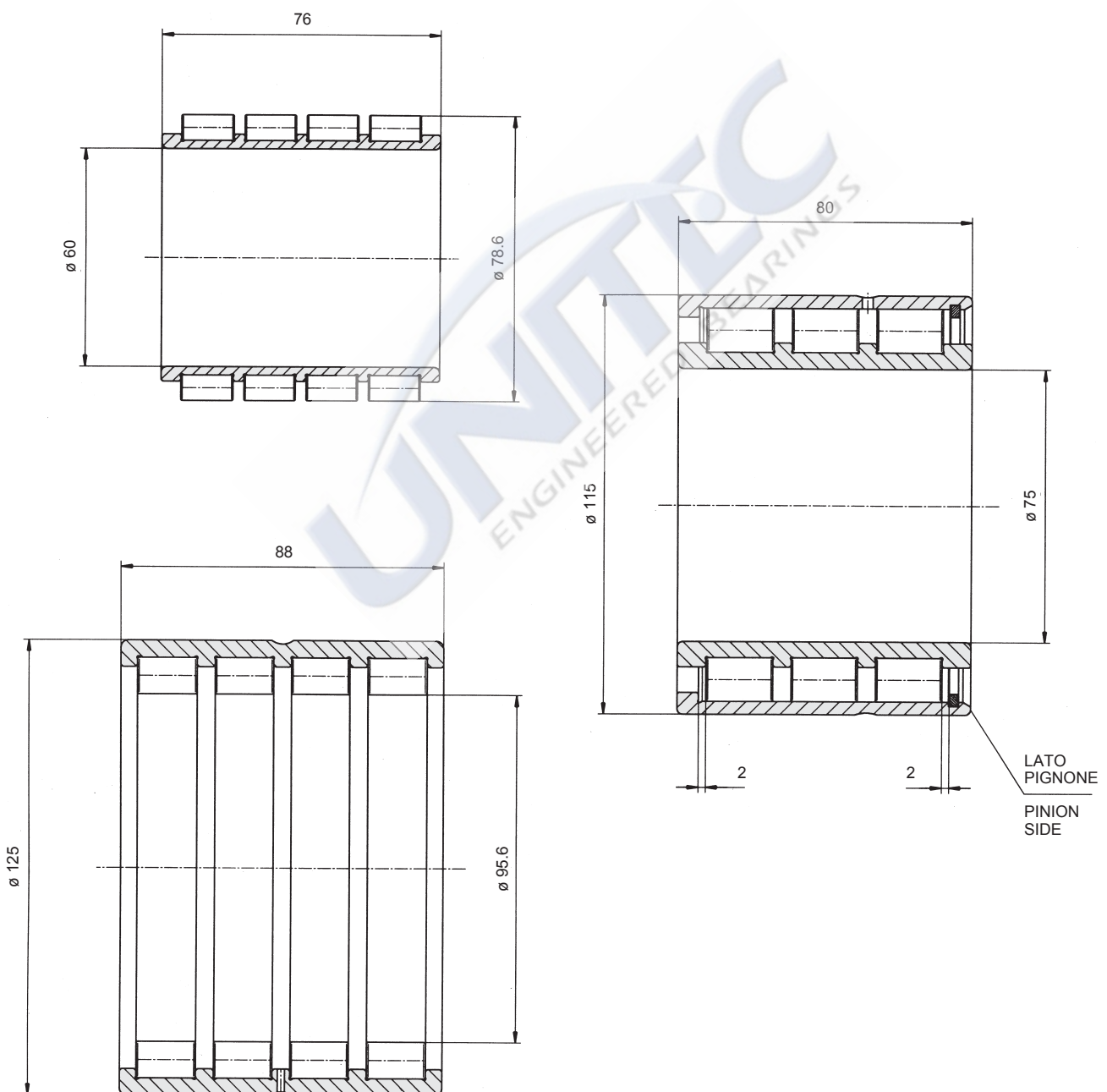

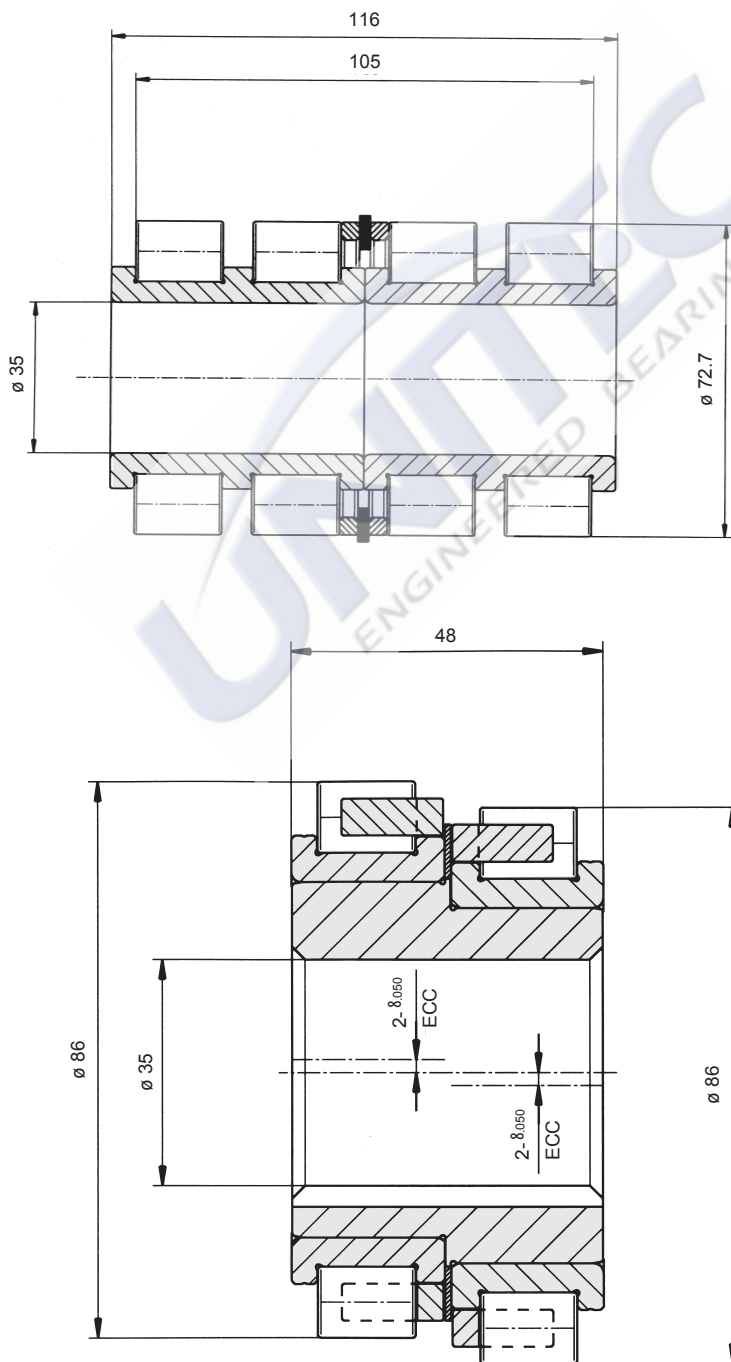

OTHER PRODUCTS ALTRI PRODOTTI

Customized ball bushings, integrated solutions.

Bussole di scorrimento assiale, manicotti speciali, soluzioni integrate.

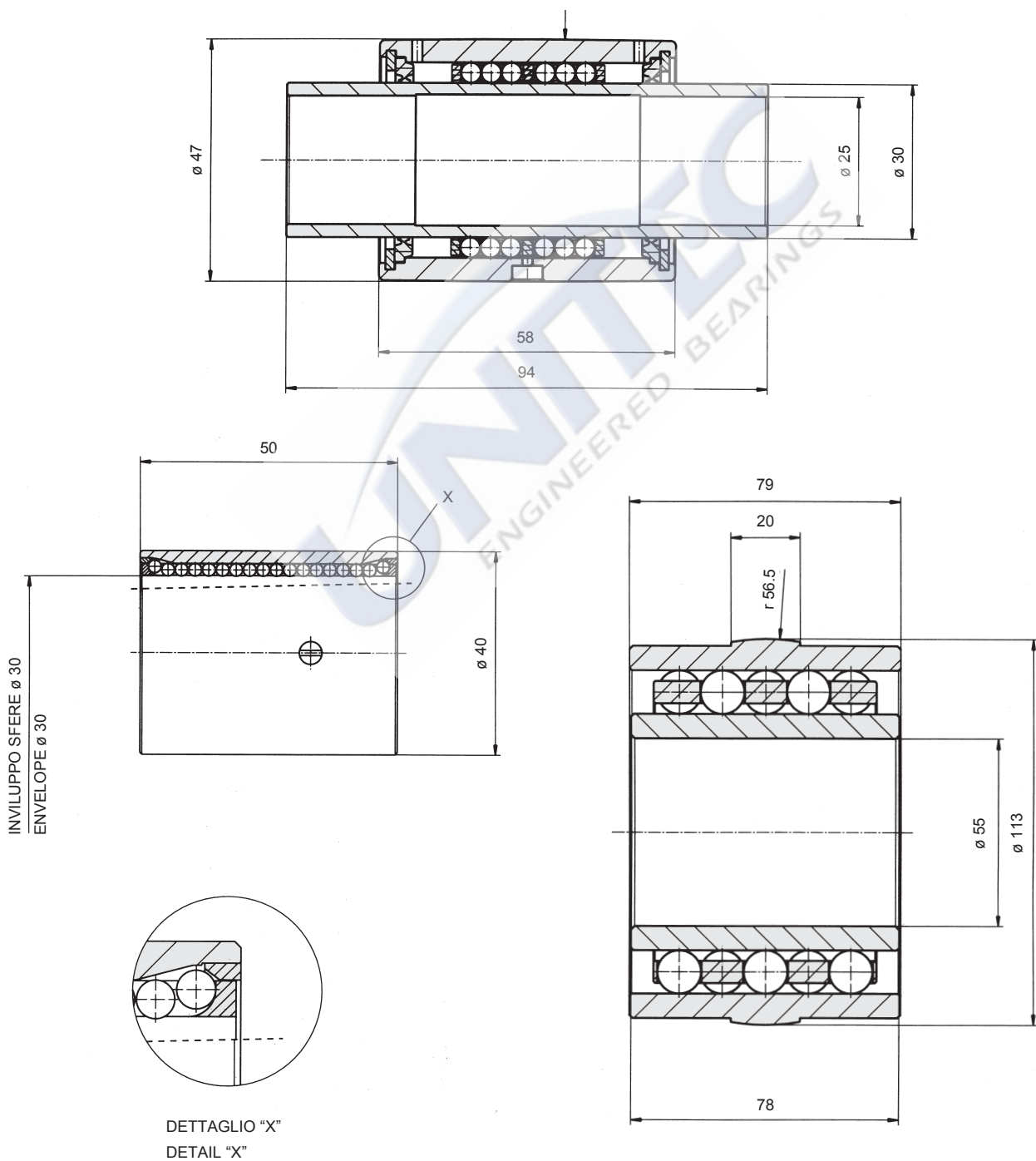

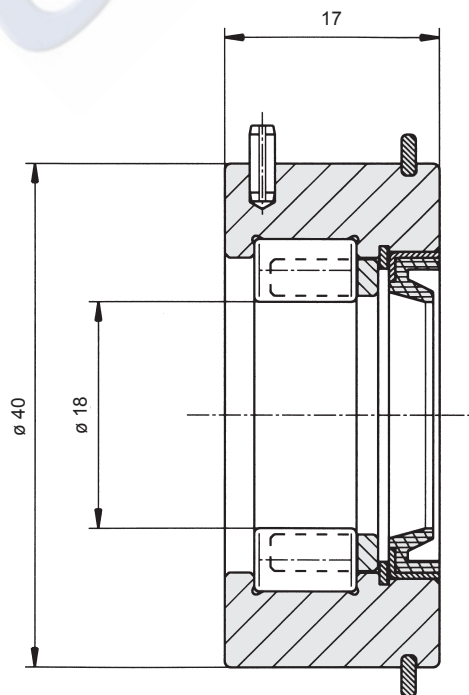
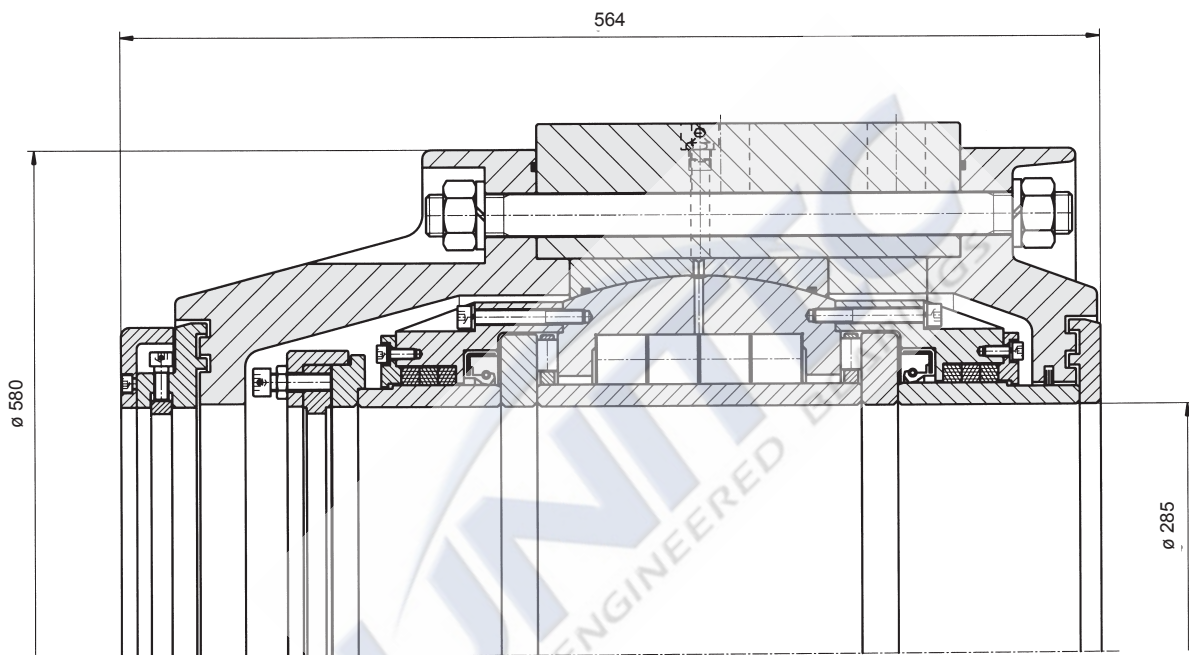





Questo catalogo è stato redatto con la massima attenzione,
i dati in esso contenuti sono stati controllati accuratamente.
Non possiamo in ogni caso accettare alcuna responsabilità
per eventuali errori od omissioni.

Ci riserviamo di apportare modifiche anche parziali, dovute alla costante
evoluzione tecnica dei nostri prodotti.

Tutti i diritti riservati. La produzione, anche parziale,
non è ammessa senza nostra autorizzazione.

I cataloghi Unitec possono essere scaricati dal sito: www.unitecbearings.com

This catalogue has been produced with a great deal of care and
attention and all data have been checked for their accuracy.
However, no liability can be assumed for any incorrect
or incomplete data.

Due to constant development and expansion of the product range,
we reserve the right to make modifications.

All rights reserved. Reproduction in whole or in part
without our authorization is prohibited.

Unitec catalogues are available for download on: www.unitecbearings.com



MONDIAL
GROUP

Mondial Group in Italy
Gruppo Mondial in Italia



MONDIAL S.p.A.
Via G. Keplero, 18 · I - 20124 Milano
www.mondial.it
Email: mkt@mondial.it

Sales office/Ufficio commerciale
Tel. +39 02 668101

Filiale di Bologna
Tel. +39 051 4199411

Filiale di Firenze
Tel. +39 055 8974470



UNITEC S.r.l.
Via G. Keplero, 18 · I - 20124 Milano
www.unitecbearings.com
Email: info@unitecbearings.com

Sales office/Ufficio commerciale
Tel. +39 02 668101
Fax +39 02 66810252

Unità produttiva
29010 S. Nicolò di Rottofreno (PC)



TMT S.r.l.
Via Tonale, 5 · I - 20125 Milano
www.tmtlinearsystems.com
Email: tmt@tmtlinearsystems.com

Sales office/Ufficio commerciale
Tel. +39 02 668101
Fax +39 02 67076787

Unità produttiva
29015 Castel San Giovanni (PC)

AZIENDA CON SISTEMA
DI GESTIONE QUALITÀ
CERTIFICATO DA DNV GL
= ISO 9001 =



AZIENDA CON SISTEMA
DI GESTIONE QUALITÀ
CERTIFICATO DA DNV GL
= ISO 9001 =

AZIENDA CON SISTEMA
DI GESTIONE AMBIENTALE
CERTIFICATO DA DNV GL
= ISO 14001 =

AZIENDA CON SISTEMA QUALITÀ
CERTIFICATO DA BUREAU VERITAS
ISO 9001:2008

Mondial Group in Europe
Gruppo Mondial in Europa



A company of the Mondial Group

ITM-UNITEC GmbH
Kuchengrund 38 · D - 71522 Backnang
www.itm-unitec.com
Email: info@itm-unitec.com

Sales office/Ufficio commerciale
Tel. +49 (0)7191 495 265 0
Fax +49 (0)7191 495 265 10

Mondial / Bianchi Group
Gruppo Mondial / Bianchi



RJ INTERNATIONAL
VALAD - La Bastide Blanche Bat B2
F - 13127 Vitrolles
www.rj-international.fr
Email: info@rj-international.fr

Sales office/Ufficio commerciale
Tel: +33 (0)4 42 75 29 57
Fax: +33 (0)4 42 89 24 80



ANTIFRICTION COMPONENTS Ltd
Unit A Causeway Central Pioneer Park
UK - Bristol BS4 3QB
www.antifriction.co.uk
Email: info@antifriction.co.uk

Sales office/Ufficio commerciale
Tel: +44 (0)117 9588 908
Fax: +44 (0)117 9713 032



RODAMIENTOS FEYC S.A.
C/Progrés, 127-133 Pol. Ind. Almeda
E - 08940 CORNELLÀ DE LL. (Barcelona)
www.feyc.es
Email: feyc@feyc.es

Sales office/Ufficio commerciale
Tel: +34 (0)934 740 464
Fax: +34 (0)934 745 893